

Laser Distance Sensors D-Series

Type DAN-10-150

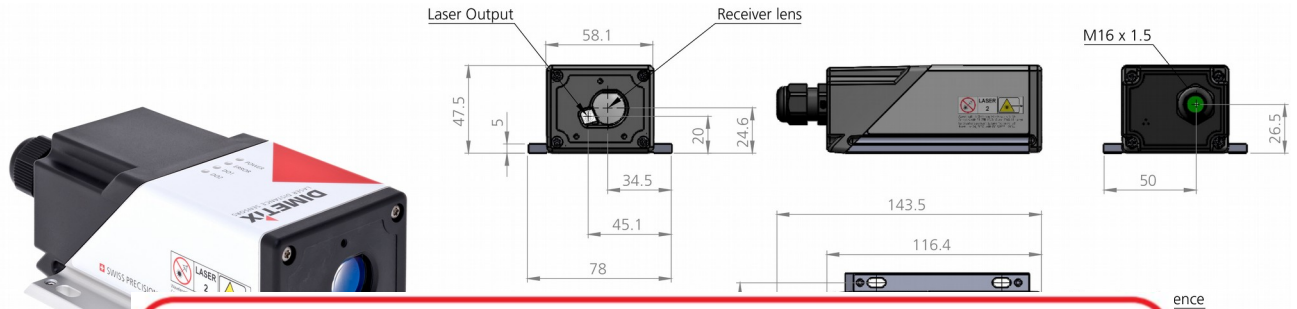

DOCUMENTO OBSOLETO

Ver la nueva versión en
 la web www.guemisa.com

Part No. 500632

SPECIFICATION

Typical accuracy @ $\pm 2\sigma$ (@ $\pm 1\sigma$)	± 1 (± 0.5) mm
Typical repeatability @ $\pm 2\sigma$ (@ $\pm 1\sigma$)	± 0.3 (± 0.15) mm
Measuring range on natural surfaces	0.05...~100 m
Measuring range on reflective foil	~40...150 m
Max. measuring rate	50 Hz
Max. output rate	50 Hz
Operating temperature	-10...+50°C
Degree of protection	IP65
Power supply	12...30 VDC (0.15A @ 24 VDC)
Laser red, visible (Laser Class 2, <1mW)	✓
Typical diameter of laser dot @ 10, 50, 100 m	7 x 3 mm; 28 x 13 mm; 55 x 30 mm
Dimension (L x W x H)	140 x 78 x 48 mm
Weight	350 g

INTERFACES

Analog output, programmable	0/4...20 mA
Max. error analog output	± 0.1 %
Digital input, programmable	1
Digital output, programmable / error display (Type: NPN, PNP, Push-Pull)	2 / 1
Serial Interfaces: RS-232, RS-422 / RS-485, SSI	✓
USB, only for configuration	✓
Optional: PROFIBUS (external) / PROFINET / EtherNet/IP / EtherCAT	✓

CONNECTION

Internal screw terminals	✓
--------------------------	---

Subject to change without notice. Further our General Terms and Conditions of Sale and Supply ("GTC") are valid.

